



Seiho International, Inc.

# SUBMITTAL SHEET

www.seiho.com

## Model: **SB-P/SB-PH** Dryer Vent

- Standard with Back-Draft Flapper Damper
- With Heavy Duty 8 1/2" Long Aluminum Pipe
- Large Free Area Reduces Clogging
- Ø3/16" Mounting Holes (SB-PH)

- Material: Aluminum
- Standard Finish: Clear Anodized

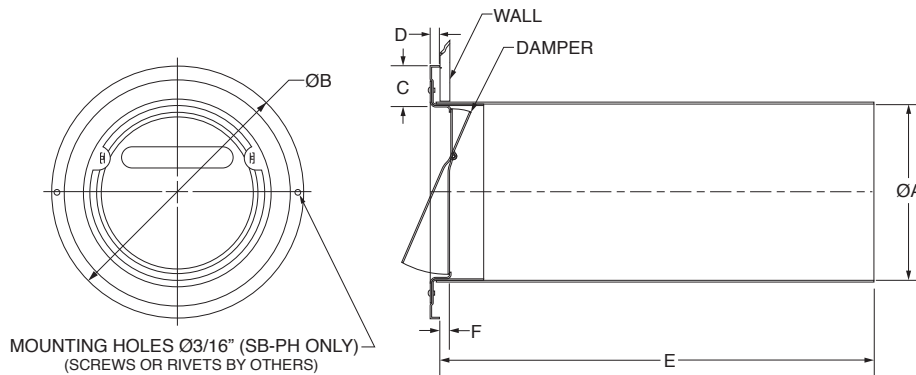

MODEL	A	B	C	D	E	F	FREE AREA
SB 4P/SB 4PH	4	5 3/4	1 7/8	9/32	8 1/2	7/32	0.059 sq.ft.
SB 6P/SB 6PH	6	7 3/4	1 7/8	9/32	8 1/2	1/2	0.140 sq.ft.

Product information is subject to change without notice. All dimensions in inches.

JOB NAME: \_\_\_\_\_  
 LOCATION: \_\_\_\_\_  
 ARCHITECT: \_\_\_\_\_  
 ENGINEER: \_\_\_\_\_  
 CONTRACTOR: \_\_\_\_\_

SUBMITTED BY: \_\_\_\_\_

DATE: \_\_\_\_\_

**Model SB-P/SB-PH**  
Dryer Vent

Form No.467-26-b