

Model: SFB Aluminum Dryer Vent

- With Back-Draft Flapper Damper
- Large Free Area Reduces Clogging
- Aluminum Construction
- Anodized Finish for Corrosion Protection

- Material: Aluminum
- Standard Finish: Anodized

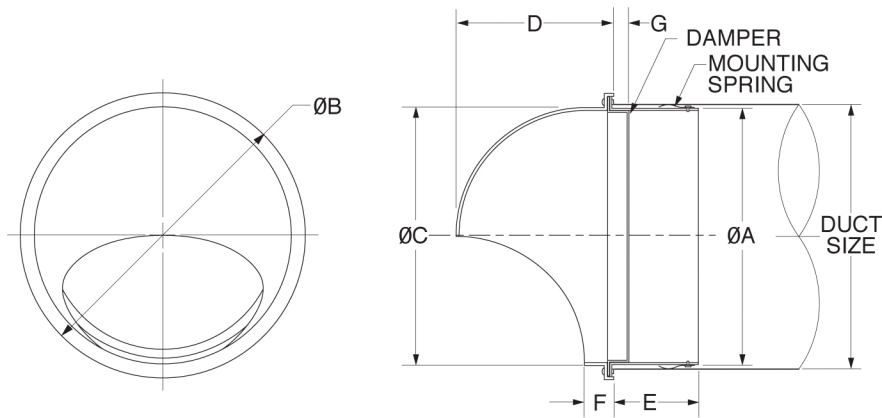

MODEL	DUCT SIZE	A	B	C	D	E	F	G	FREE AREA
SFB 4	100	96	121	96	68	40	21	8	50.22sq.cm
SFB 6	150	147	175	150	100	65	21	9	120.9sq.cm

Dimensions are in millimeters. Product Information is Subject to Change Without Notice.

JOB NAME: _____
 LOCATION: _____
 ARCHITECT: _____
 ENGINEER: _____
 CONTRACTOR: _____

SUBMITTED BY: _____

DATE: _____

Model SFB
Aluminum Dryer Vent

Form No.383S-M